

WORKING DIMENSIONS

Length:	3.5 m (16 ft. 5 in.)
Width:	2.8 m (14 ft. 1 in.)
Height:	3 m (9 ft. 10 in.)
Weight:	2.2 tons (pump excluded)

INTERNATIONAL SHIPPING DIMENSIONS

Shipping Method:	One (1) containers 40'
------------------	------------------------

FLOTATION

Dimensions:	Two pontoons 3.5 m x 1 m x 1.25 m with Central Platform
Draft:	80 – 90 cm

WORKING CAPACITY

Capacity:	30 m ³ /h – 70 m ³ /h (132 gpm – 308 gpm)
Head:	21 m – 12 m (68 ft. – 39 ft.)
Working Depth:	Up to 30 m (98 ft.)

SUBMERSIBLE DREDGE PUMP

Type:	EL5	EL12,5
Discharge Diameter:	80 mm	100 mm
Impeller Diameter:	245 mm / 4 blades open	308 mm / 4 blades open
Max. Solid Handling:	20 mm	25 mm
Speed:	1.450 rpm	1.450 rpm
Phases	3	3
Frequency	50/60 Hz	50/60 Hz
Voltage	On request	On request
Insulation Class	H	H
Power:	3.7 kW	9 kW
Capacity:	30 m ³ /h	70 m ³ /h
Head:	12 m	16 m
Working Depth:	Up to 30 m (98 ft.)	Up to 30 m (98 ft.)

POWER SOURCE

Type:	On-shore Electric Power Generator
Minimum required Power:	50 kVA

JET RING SYSTEM

Water capacity:	20 m ³ /h
Pressure:	6 bar – 7 bar
Drive:	On-barge horizontal high pressure pump

This dredge can be equipped with different pump. For any questions and special requests, please contact one of our sales representatives.

PROPULSION

Standard	Two (2) 50 m steel Winches (available up to 110 m)
Secondary System:	Helix Propeller (OPTIONAL)

ELECTRICAL SYSTEM

Voltage:	On request
----------	------------

SAFETY

Features	Completely remote controlled dredge with no operators on-board. The dredge is controlled from up to 500m away from a remote control, greatly reducing the risk to the operators.
----------	--

ANTI-CORROSION FEATURES

Includes:	Hull below deck painted with marine-grade epoxy. Hull above deck painted with polyurethane epoxy and remaining components coated with heavy-duty powder coating all suitable for salt-water service.
-----------	--

EQUIPMENT	BASIC	STANDARD	FULL OPTIONAL
Winches for moving	X	X	X
Night time operating lights	X	X	X
Electric Hoist	X	X	X
Control Panel	X	X	X
Temperature Sensor		X	X
Pond Bottom Liner Protection		X	X
Digital Depth Gauge		X	X
Power Consumption		X	X
Jet-Ring System			X
Moisture Sensor			X
Dredge GPS System			X
Helix Propeller			X

ANTI-CORROSION PACKAGE AVAILABLE ON REQUEST (PH 2 – 12)

The setups in the table above are referential. The final setup for the dredges is determined upon studying the client's needs.



THE DREDGE

Jet Ring System

- On-barge horizontal, high pressure water pump
- Suction and Discharge hoses included
- Water flow: 20 m³/h
- Pressure: 6 bar – 7 bar

Electric Control Panel

- Complete Control panel
- Connection for Power cable
- Regulates pump start-up with Reactor starter
- Distributes Power to all components on the dredge.

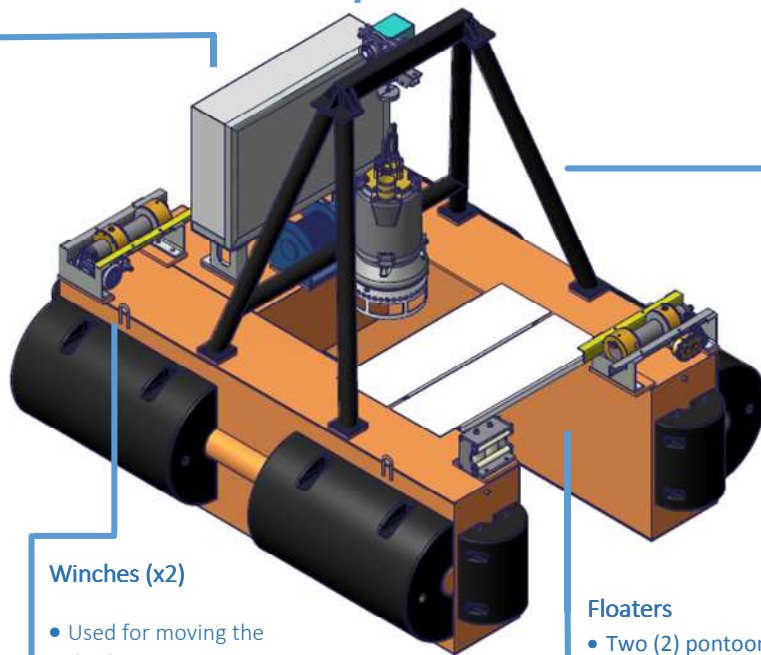

Winches (x2)

- Used for moving the dredge
- Steel cables
- Optional propeller

Floaters

- Two (2) pontoons 3.5 m x 1 m x 1.25 m with central platform
- Small draft



Electric Hoist

- Carefully move pump up and down
- Depth measuring pulley



THE PUMP

Jet-Ring System

- High pressure water jets used to rupture the material and have a higher solid concentration in the mixture
- Water Capacity: 20
- Pressure: 6 bar – 7 bar
- Drive: Horizontal high pressure pump

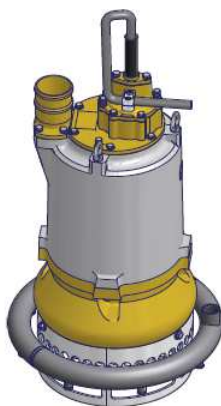

Pump

- Capacity: 30 m³/h – 70 m³/h
- Head: 16 -12 m
- Discharge diameter: 80mm – 100mm
- Suction diameter: 415 mm
- Impeller diameter: 245 mm – 308 mm
- Max. solid handling: 20 – 25 mm
- Speed: 1.450 r.p.m.

Remote Control

- Turn pump ON/OFF
- Jet-Ring ON/OFF
- Move pump up and down
- Move dredge sideways
- Emergency stop
- Display with working depth and power consumption

